









Wall Microwave Cabinet Assembly Instruction

(Item:WMC2430 WMC2436 WMC2442 WMC2730 WMC2736 WMC2742)

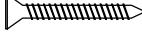
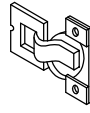
Hardware list	1 8pcs $\varnothing 4 \times 16\text{mm}$ Flat head screw	2 4pcs $\varnothing 4 \times 19\text{mm}$ Round head screw	3 8pcs $\varnothing 3.5 \times 14\text{mm}$ Color galvanized screw with flat head	4 6pcs $\varnothing 3.5 \times 16\text{mm}$ Color galvanized screw with flat head	5 6pcs $\varnothing 3.5 \times 35\text{mm}$ Black screw with flat head	6 4pcs 1-1/4" Hinge	7 6mm Shelf clips
							
Assembly tools required	Screw driver	Rubber mallet			10 4pcs 40mmx40mm Bracket rainbow 90°	9 4pcs $\varnothing 7$ Bumper	8 2set L-shape bracket
							
Cabinet Part List	A Front frame	B side panels(2)	C Top&Bottom panel	D Fixed shelf	E Back panel	F Door	G Arc bottom panel

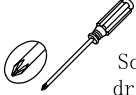
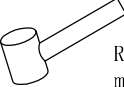
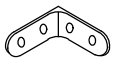
Step 1 : With front frame (A) of cabinet lay down on clean and soft surface then put glue into groove.

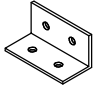
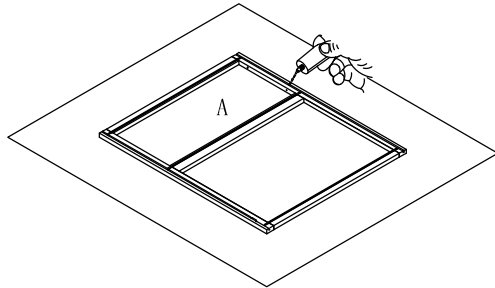

Step 2 : Install side panels. Insert two side panels (B) into groove of front frame (A) until side panel (B) and front frame (A) even.

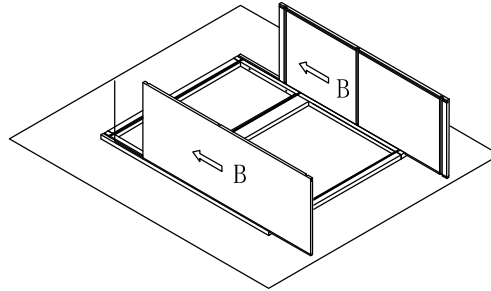

Step 3 : Install top&bottom panel(C) and fixed panel(D). Insert top&bottom panel (C) and fixed panel(D) into groove of side panel (B) until it into the groove of front frame (A).

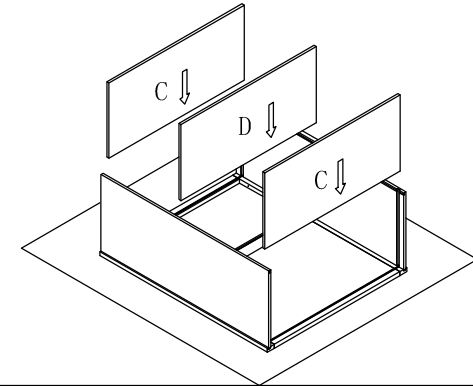

Step 4 : Install back panel. Insert back panel(D) until the top and bottom panels into groove of back panel and screw L-shape bracket to the frame and top&bottom panel.

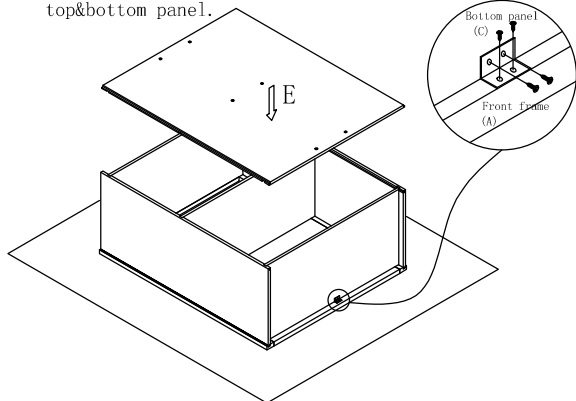

Step 5 : Screw rainbow bracket into front frame(A) and side panel(B).

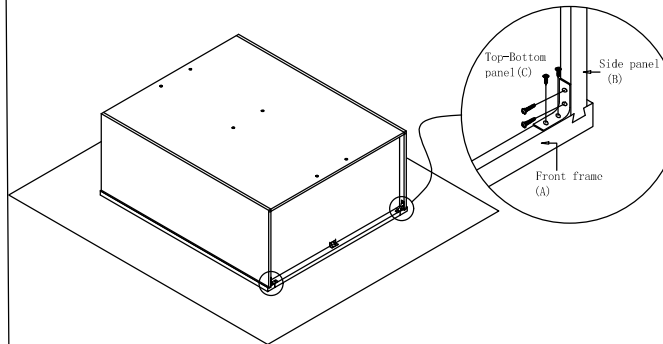

Step 6 : Install assembly screws into back panel. then nails side panel (B) and back panel (C) using nail gun.

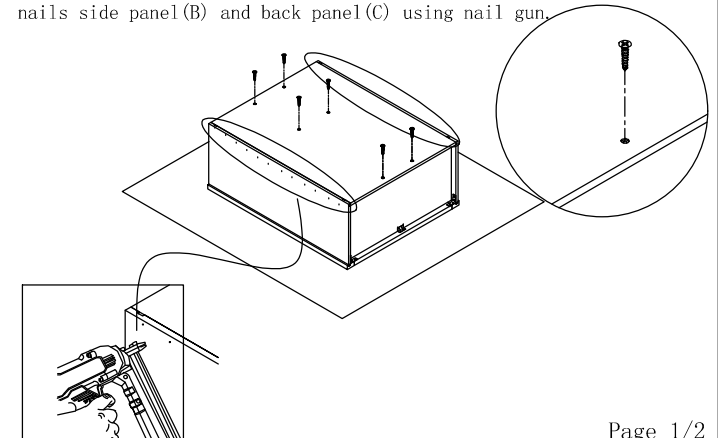

Wall Microwave Cabinet Assembly Instruction

(Item:WMC2430 WMC2436 WMC2442 WMC2730 WMC2736 WMC2742)

Step 7 : Install rainbow bracket. Screw the rainbow bracket to the side panel(B) and front frame(A) and also screw the L-shape bracket to the front frame(A) and top panel(C).

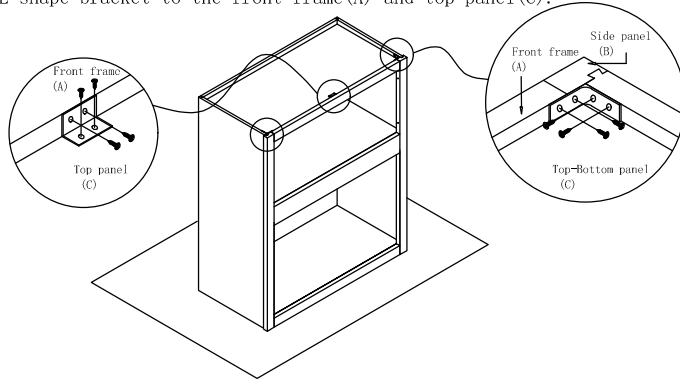

Step 8 :Install door. Screw the hinge to the door (F) and front frame (A).

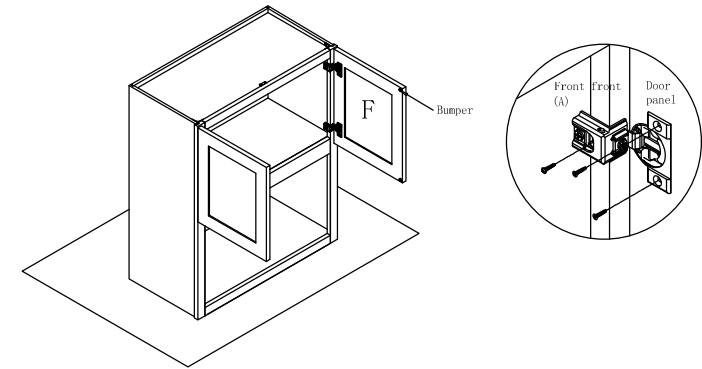

Step 9 : Install arc bottom panel. Put the arc bottom panel on the bottom panel.

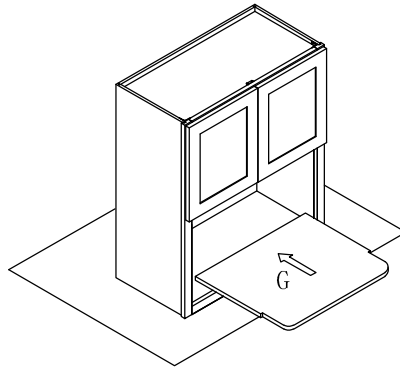

Step 10 : Finish installation of the cabinet.

