









# Wall Cabinet Assembly Instruction

(Item:W361224 W361524 )

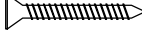
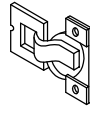
Hardware list	1   8pcs   $\varnothing 4 \times 16 \text{mm}$ Flat head screw	2   4pcs   $\varnothing 4 \times 19 \text{mm}$ Round head screw	3   8pcs   $\varnothing 3.5 \times 14 \text{mm}$ Color galvanized screw with flat head	4   6pcs   $\varnothing 3.5 \times 16 \text{mm}$ Color galvanized screw with flat head	5   4pcs   $\varnothing 3.5 \times 35 \text{mm}$ Black screw with flat head	6   4pcs   $1-1/4"$ Hinge	7   2pcs   L-shape bracket
							
Assembly tools required	Screw driver	Rubber mallet				9   4pcs   $40 \text{mm} \times 40 \text{mm}$ Bracket rainbow 90°	8   4pcs   $\varnothing 7$ Bumper
							
Cabinet Part List	A   Front frame	B   Side panel(2)	C   Top-Bottom panel	D   Back panel	E   Door		

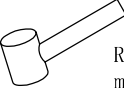
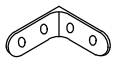
Step 1 : With front frame (A) of cabinet lay down on clean and soft surface then put glue into groove.

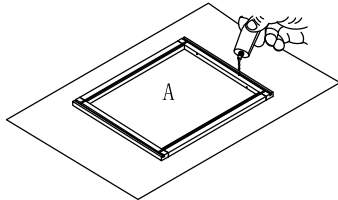

Step 2 : Install side panel. Insert two side panels (B) into groove of front frame (A) until side panel (B) and front frame (A) even.

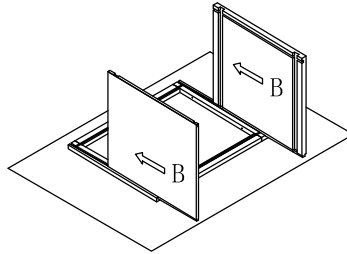

Step 3 : Install top and bottom panel. Insert top and bottom panel (C) into groove of side panel (B) until it into the groove of front frame (A).

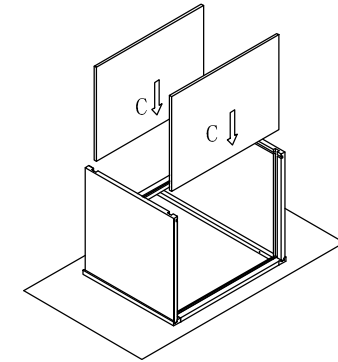

Step 4 : Install back panel. Insert back panel (D) into groove of left and right side panel (B) and screw L-shape bracket to the frame and top&bottom panel.

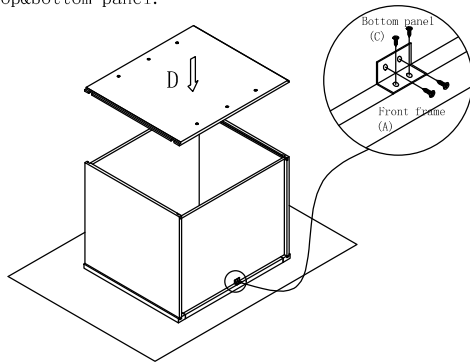

Step 5 : Screw rainbow bracket into front frame (A) and side panel (B).

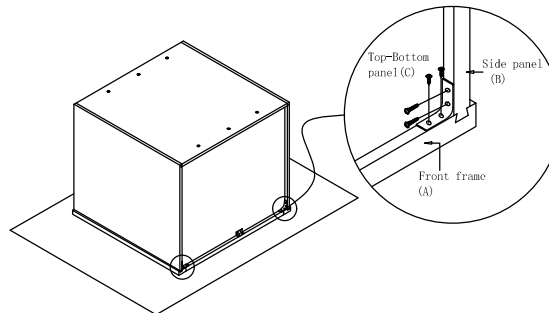

Step 6 : Install screw (5)  $\varnothing 3.5 \times 35 \text{mm}$  into back panel (D), then nails side panel (B) and back panel (C) using nail gun.

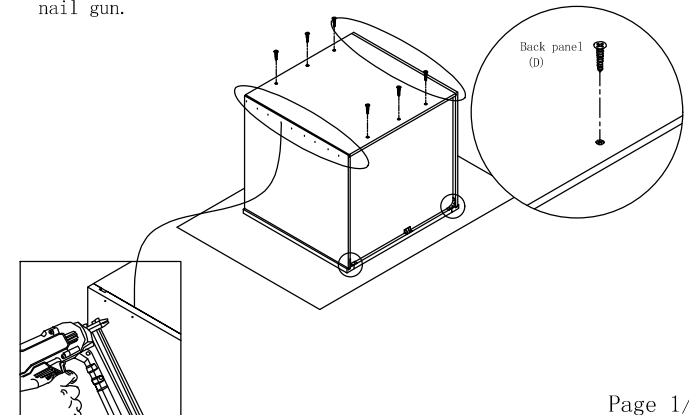

# Wall Cabinet Assembly Instruction W361224 W361524

Step 7 : Install rainbow bracket. Screw the rainbow bracket to the side panel(B) and front frame(A) and also screw the L-shape bracket to the front frame(A) and top panel(C).

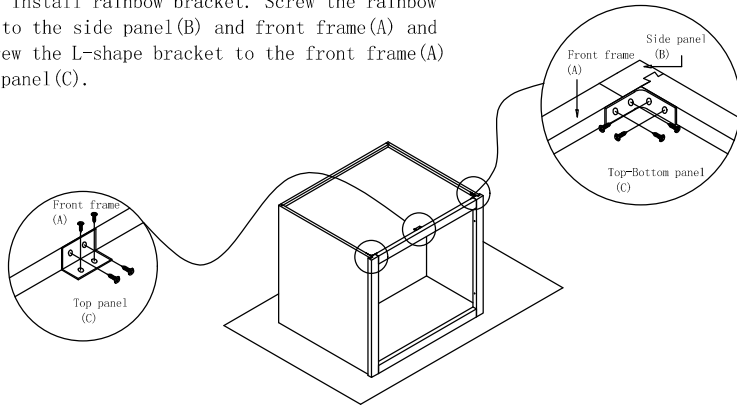

Step 8 : Install door. Screw the hinge to the door (F) and front frame (A).

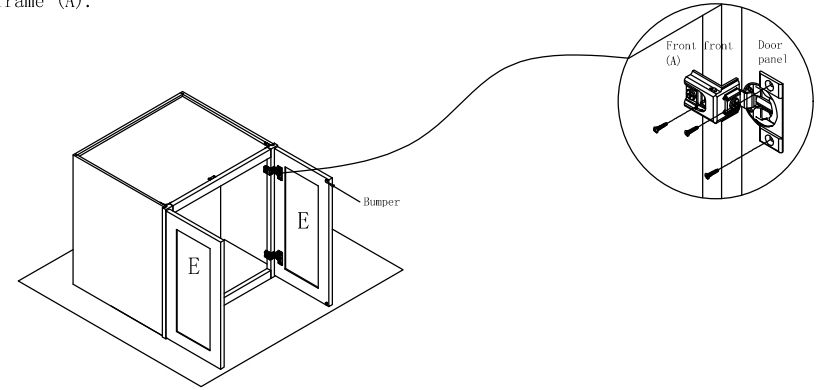

Step 9 : Finish installation of cabinet.

