

Base End Shelf Cabinet Assembly Instruction

(Item: BES09)

Hardware list	1	27pcs	Ø4x25mm						Assembly tools required		 Screw driver	 Rubber mallet
				Black screw with flat head								

Cabinet Part List	A	Small side panel(1)	B	Big side panel(1)	C	Top&Bottom panel(2)	D	Fixed shelf	E	Toe kick				
-------------------	---	---------------------	---	-------------------	---	---------------------	---	-------------	---	----------	--	--	--	--

Step 1 : With big side panel (B) of cabinet lay down on clean and soft surface then put glue into groove.

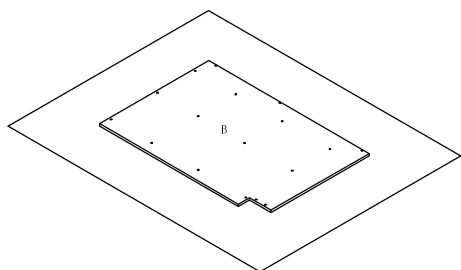

Step 2 : Assembly small side panel (A) to the big side panel (B).

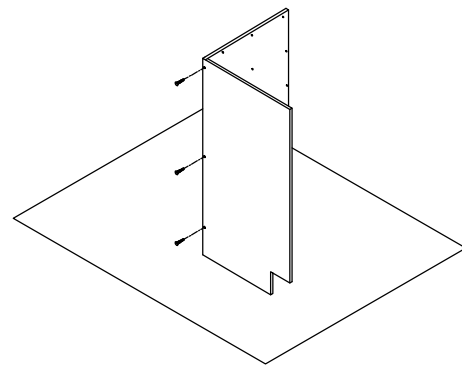

Step 3 : Assembly top&bottom panel(C) and fixed shelf(D).

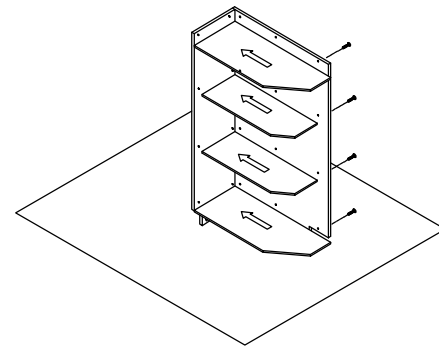

Step 4 : Install toe kick.

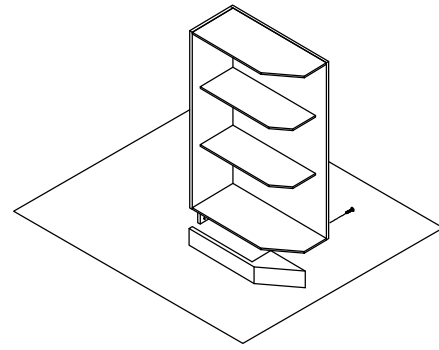

Step 5 : Finish installation of the cabinet.

