









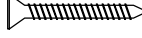
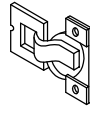

Base Cabinet Assembly Instruction

(Item: B09-B15)

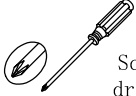
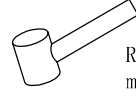
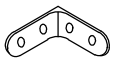
Hardware list	1 4pcs $\varnothing 4 \times 16\text{mm}$ Flat head screw	2 2pcs $\varnothing 4 \times 19\text{mm}$ Round head screw	3 20pcs $\varnothing 3.5 \times 14\text{mm}$ Color galvanized screw with flat head	4 6pcs $\varnothing 3.5 \times 16\text{mm}$ Color galvanized screw with flat head	5 1pc $\varnothing 3.5 \times 35\text{mm}$ Black screw with flat head	6 2pcs 1-1/4" Hinge	7 4pcs 6mm Shelf clips	
								
Assembly tools required	Screw driver	Rubber mallet	H Drawer part		11 4pcs 40mmx40mm Bracket rainbow 90°	10 6pcs $\varnothing 7$ Bumper	9 4set L-shape bracket	8 1set S30B533H10GA08 Drawer slide
								
Cabinet Part List	A Front frame	B Side panel(2)	C Bottom panel	D Back panel	E Toe kick panel	F Adjustable shelf	G Door	

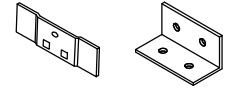
Step 1 : With front frame (A) of cabinet lay down on clean and soft surface then put glue into groove.

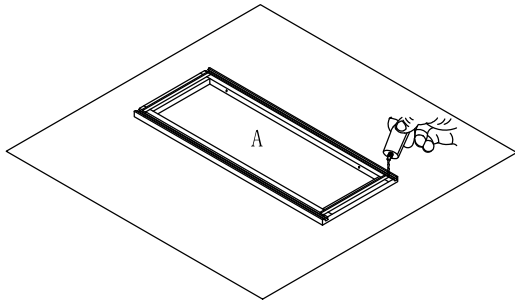

Step 2 : Install side panel. Insert both side panel (B) into groove of front frame (A) until side panel (B) and front frame (A) even.

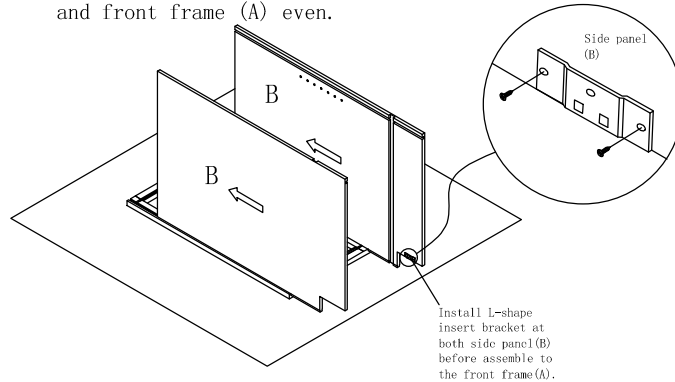

Step 3 : Install bottom panel. Insert the bottom panel (C) into groove of side panel (B) until it into the groove of front frame (A).

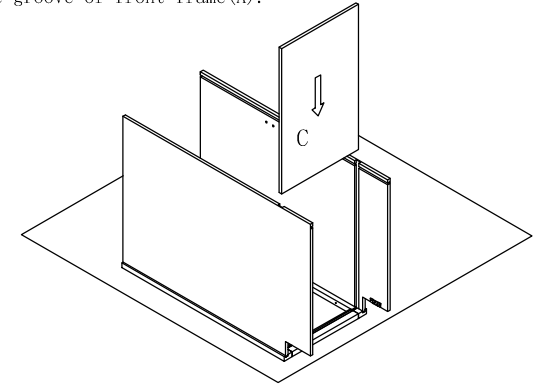

Step 4 : Install back panel. Insert back panel (D) into groove of left and right side panel (B).

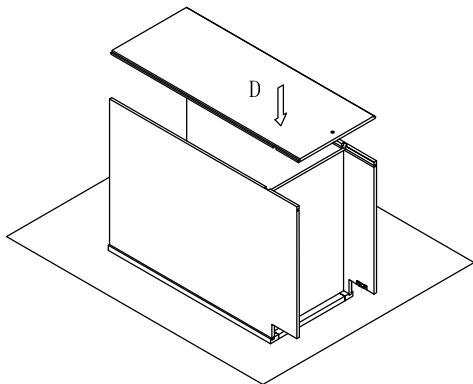

Step 5 : Install screw (5) $\varnothing 3.5 \times 35\text{mm}$ into back panel (D).

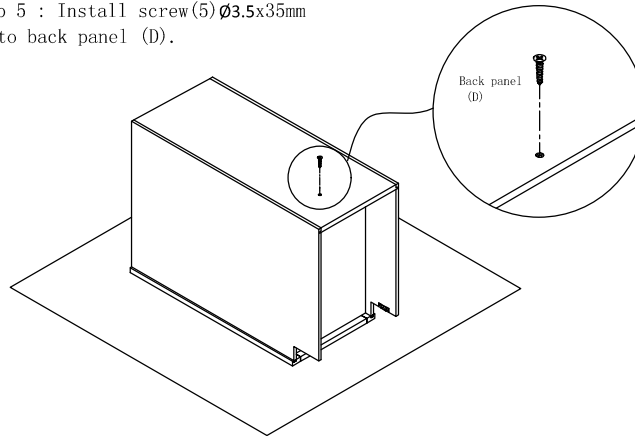

Step 6 : Install toe kick panel. Fit in the L-shape insert bracket from toe kick panel (E) into side panel (B) bracket and screw the bracket with (3) $\varnothing 3.5 \times 14\text{mm}$ screw.

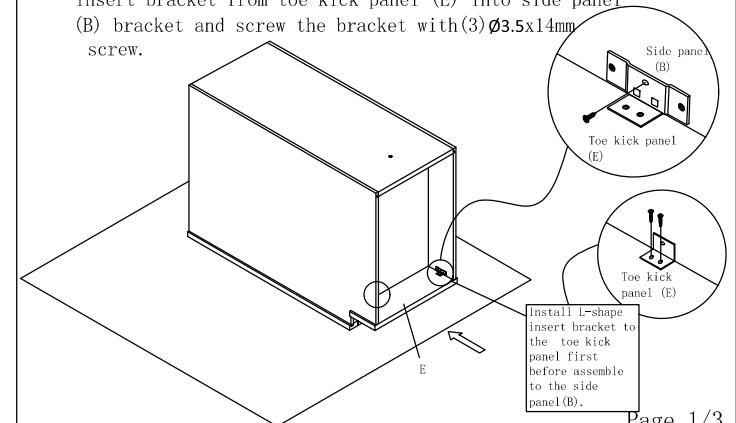

Base Cabinet Assembly Instruction

(Item: B09-B15)

Step 7 : Install back panel. Fit in the L-shape insert bracket from back panel (D) into side panel (B) and assembly the bracket with (3) $\varnothing 3.5 \times 14$ mm screw.

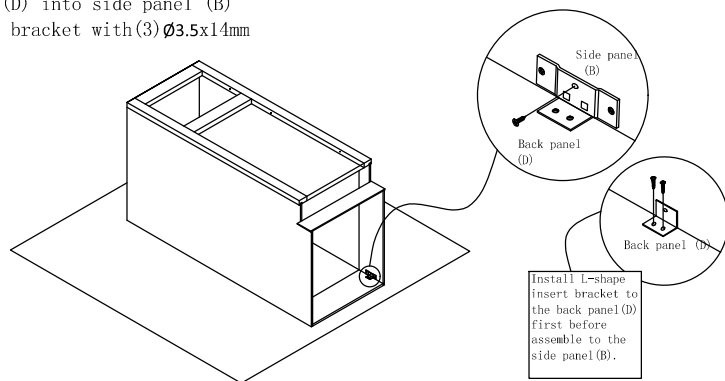

Step 8 : Install corner block. Install rainbow bracket to the side panel (B), front frame (A) and back panel (D) with the (4) $\varnothing 3.5 \times 16$ mm screw.

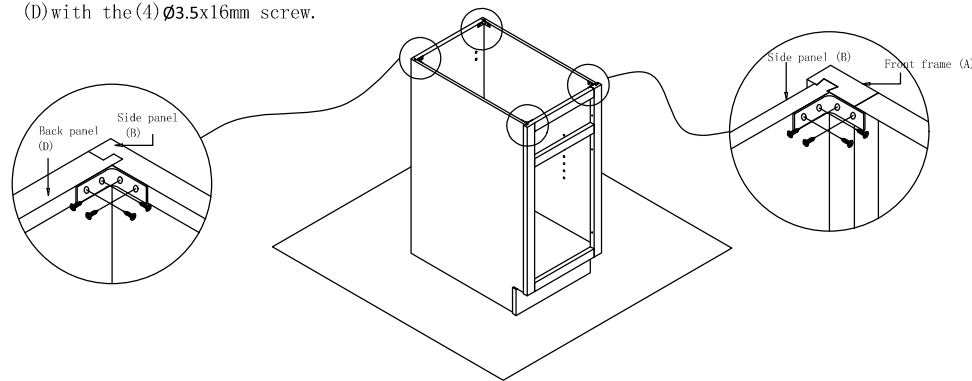

Step 9 : Install shelf clip. Install shelf clip to the side panel (B).

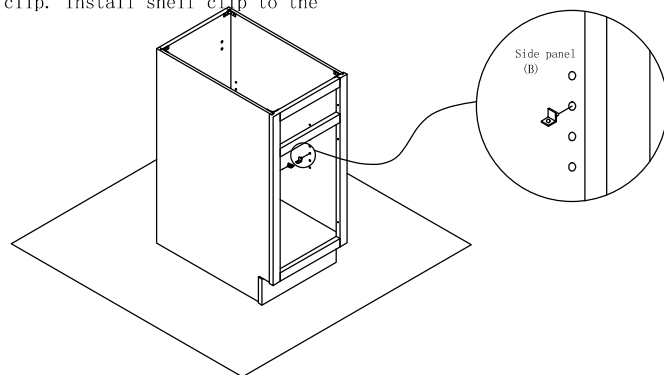

Step 10 : Install adjustable shelf. Put adjustable shelf (F) to the shelf clips.

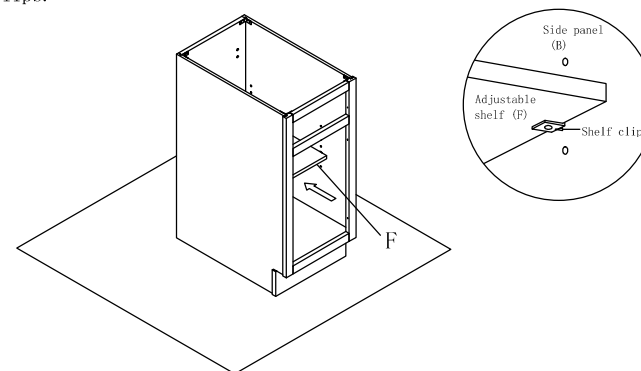

Step 11 : Install door panel (G). Screw the hinge to the front frame (A) with (2) $\varnothing 4 \times 19$ mm screw and door (G) with (1) $\varnothing 4 \times 16$ mm screw.

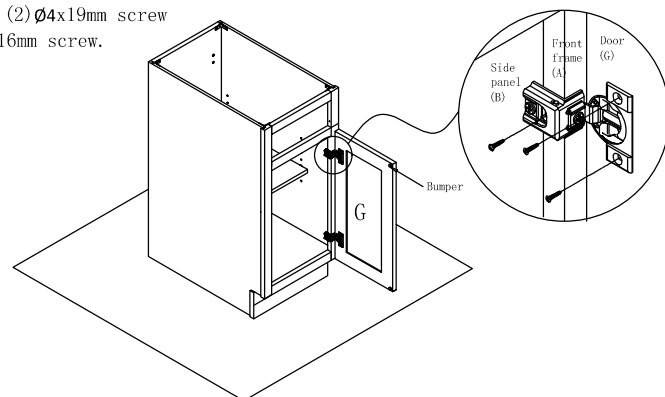

Step 12 : Install the drawer slide rear bracket. Screw the rear slide bracket to the back panel (D).

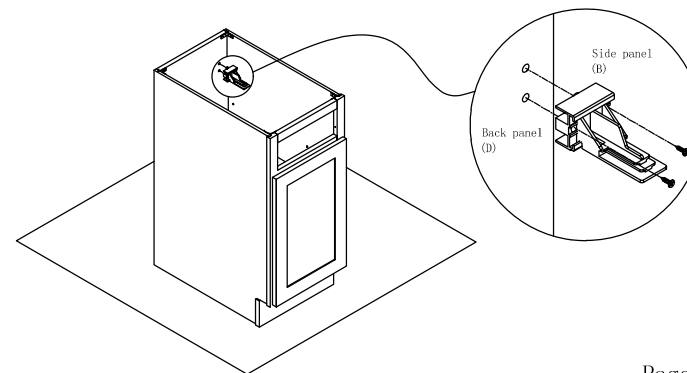

Base Cabinet Assembly Instruction

(Item: B09-B15)

Step 13 : Insert drawer slide runner to the rear slide bracket and screw the drawer side to the guide hole of front frame (A) and hole for drawer slide

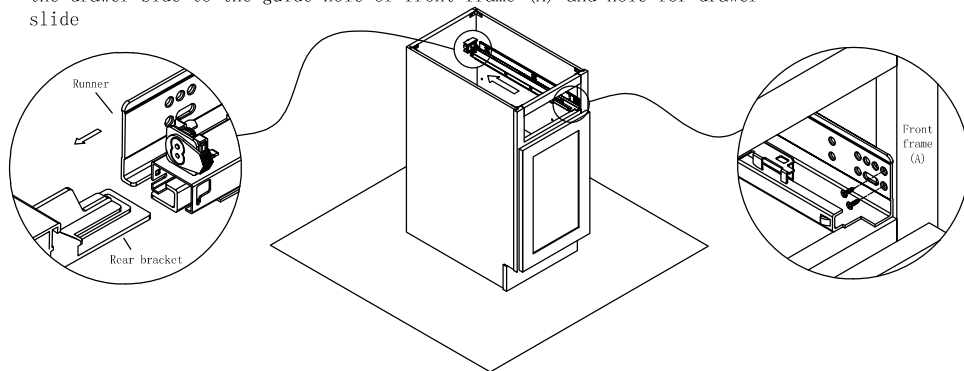

Step 14 : Put the drawer box on the drawer slide and push the drawer box to make the end of runner is lock to the hole of the drawer back panel. Complete the installation of the drawer box when you hear sound click which mean the locking device is locked on the bottom drawer hole.

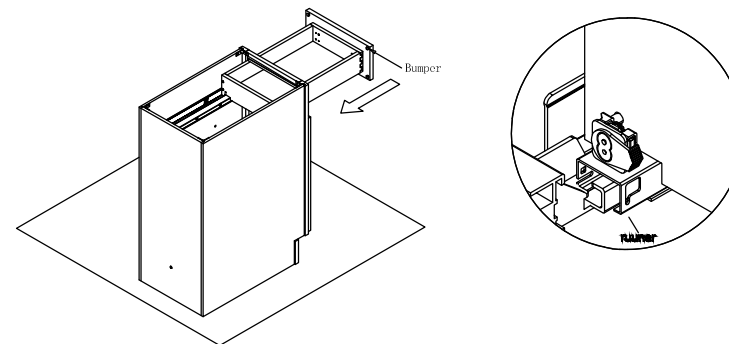

Step 15 : Finish installation of cabinet.

